

# SDL Single-Duct, Low-Height, VAV Terminals

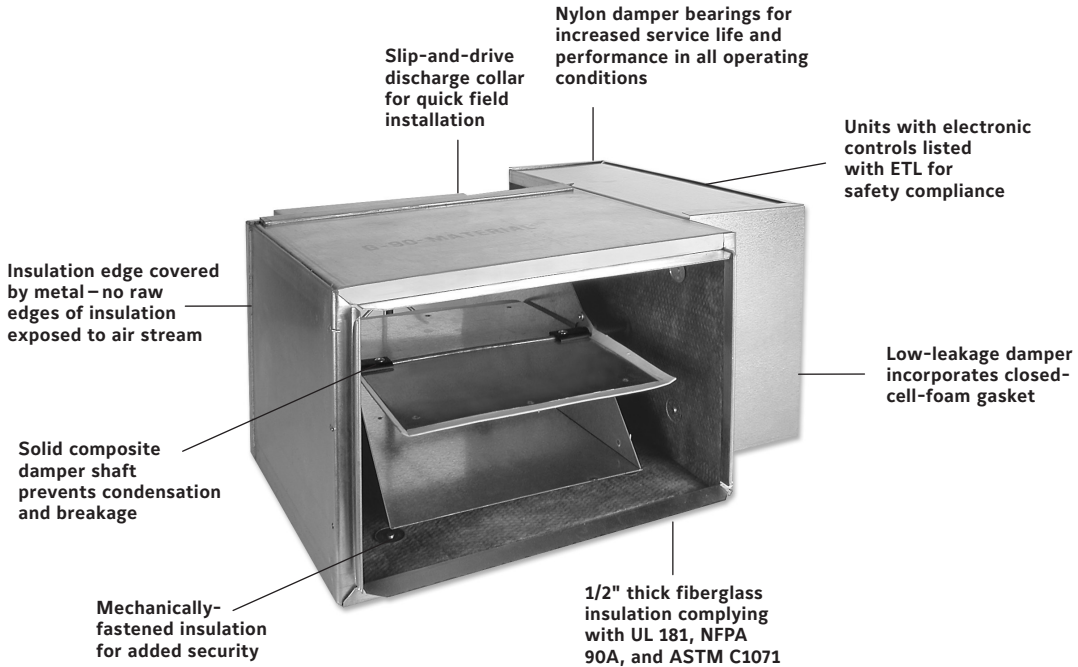

# Model SDL construction features

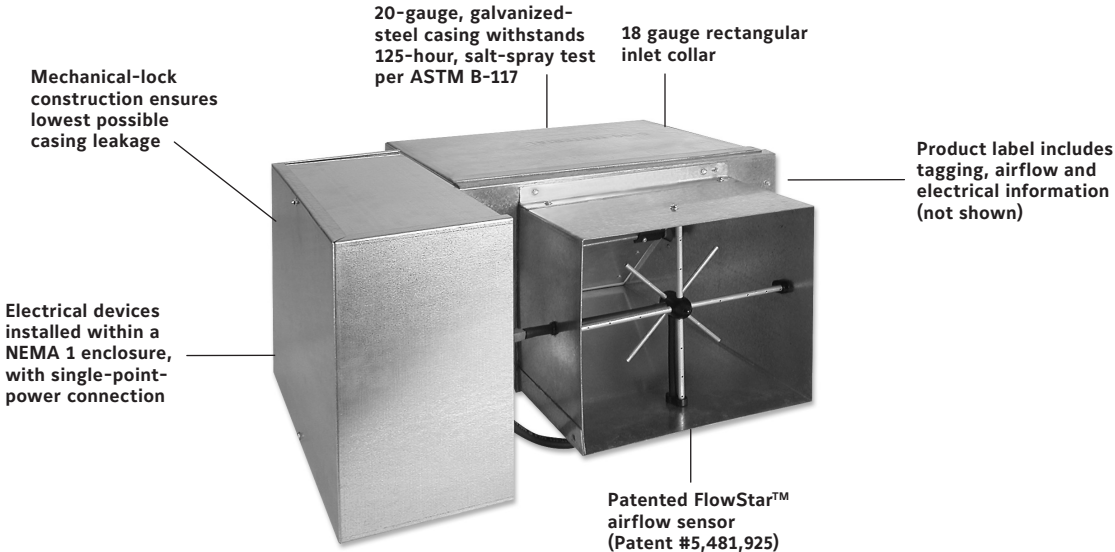

# SDL Single-Duct, VAV Terminals: Fit more comfort in less space

## Owners

SDL terminals offer the typical benefits provided by single-duct units, while performing at extremely low sound levels. This is critical in today's buildings where occupants are placing more emphasis on indoor acoustics.

In addition to quiet and accurate temperature control, the building owner will benefit from lower operating costs. The highly amplified, velocity-pressure signal from the FlowStar™ inlet sensor allows precise airflow control at low air velocities. The FlowStar™ sensor's airfoil shape provides minimal pressure drop across the terminal. This allows the central fan to run at a lower pressure and with less brake horsepower, while maintaining occupant comfort.

The SDL terminal is manufactured and assembled with a multi-point, center-averaging, airflow sensor, which provides a signal to the controller enabling it to quietly and precisely measure airflow. Superior flow measuring allows control at lower minimum cubic-feet-per-minute (CFM) values, which reduces energy costs and sound levels.

## Designers

SDL terminals provide variable-air-volume (VAV) control beyond the typical single-duct box. Only 10" in height, the compact cabinet design and quiet operation give the system designer the option to place units directly above occupied spaces. It is not necessary to locate the unit in the crowded space above a hall or corridor. This reduces lengthy and expensive discharge-duct runs.

The SDL terminal provides the ultimate in airflow control with the patented FlowStar™ airflow sensor. No other sensor in the industry can match the FlowStar's ability to quietly and precisely measure airflow. The FlowStar™ sensor ensures accurate control, even when space constraints do not permit long, straight, inlet-duct runs to the terminal.

All metal components are fabricated from galvanized steel. Unlike most manufacturers' terminals, the SDL is capable of withstanding a 125-hour, salt-spray test without showing any evidence of red rust.

Model SDL terminals are available in four unit sizes (10, 12, 14 and 16) to handle airflow capacities up to 4100 CFM.

## Contractors

Physical installation is simple with low-profile, compact design and standard metal hanging straps. And control-installation time is minimized with the availability of factory-mounted and calibrated controls. Controls are located on the outside of the unit casing for easy access by maintenance personnel.

A standard, single-point, main-power connection is provided with all electronic controls and electrical components located on the same side of the casing, for quick access, adjustment, and troubleshooting.

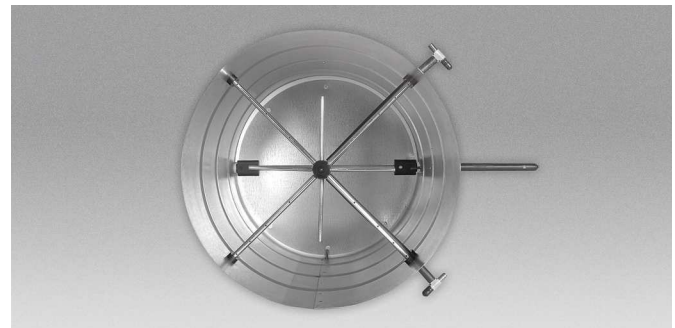

FlowStar™ airflow sensor

The FlowStar™ sensor ensures accurate airflow measurement, regardless of the field-installation conditions. A calibration label and wiring diagram is located on the terminal for quick reference during start-up.

SDL terminals require no periodic maintenance and provide trouble-free operation.

Model SDL terminals with electronic controls and/or electric heat are listed with ETL as an assembly, and bear the ETL label. SDL terminals and accessories are wired in compliance with all applicable NEC requirements and tested in accordance with AHRI Standard 880.



## Model SDL

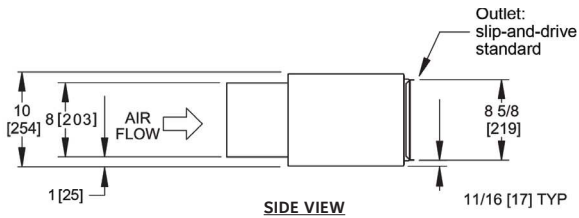
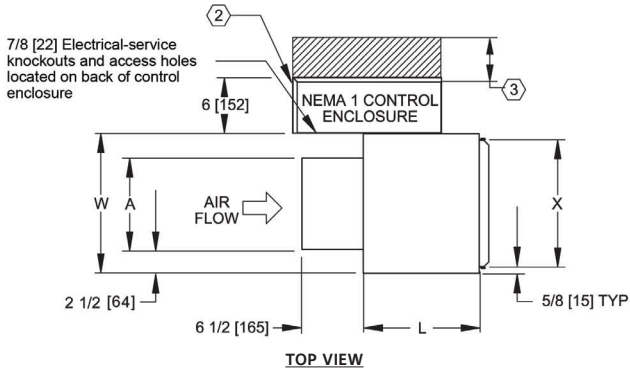

Unit Size	Dimensions				Total Weight	
	A	W	L	X	Single Wall	Double Wall
10	10" [254]	15" [381]	12-1/2" [318]	13-3/4" [349]	26 [12]	30 [14]
12	14" [356]	19" [483]	12-1/2" [318]	17-3/4" [451]	28 [13]	35 [16]
14	20" [508]	25" [635]	16-1/2" [419]	23-3/4" [603]	39 [18]	47 [21]
16	26" [660]	31" [787]	16-1/2" [419]	29-3/4" [756]	45 [20]	55 [25]

## Model SDL-WC (Hot-Water Coil)

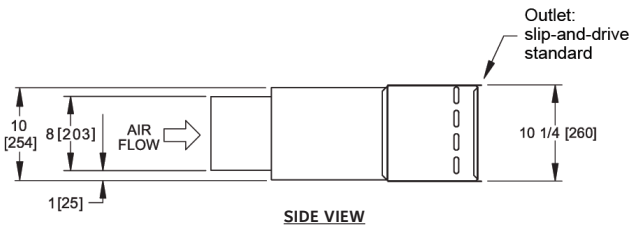
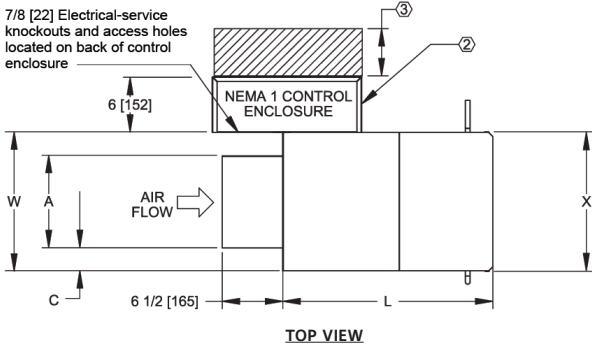

Unit Size	A	C	W	Length L		X
				1,2,3 Row Coil	4 Row Coil	
10	10" [254]	6-1/2" [165]	19" [483]	18-1/2" [470]	19-1/2" [495]	18-3/4" [476]
12	14" [356]	8-1/2" [216]	25" [635]	18-1/2" [470]	19-1/2" [495]	24-3/4" [629]
14	20" [508]	8-1/2" [216]	31" [787]	22-1/2" [572]	23-1/2" [597]	30-3/4" [781]
16	26" [660]	7-5/8" [194]	38" [965]	22-1/2" [572]	23-1/2" [597]	37-3/4" [959]

Unit Size	Coil Weights (Add to SDL unit weight)							
	1 Row		2 Row		3 Row		4 Row	
	Dry	Wet	Dry	Wet	Dry	Wet	Dry	Wet
10	8 [4]	9 [4]	10 [4]	12 [5]	12 [5]	15 [7]	14 [6]	18 [8]
12	10 [4]	11 [5]	12 [5]	15 [7]	15 [7]	19 [9]	17 [8]	23 [10]
14	11 [5]	13 [6]	14 [6]	18 [8]	17 [8]	22 [10]	20 [9]	27 [12]
16	13 [6]	15 [7]	17 [8]	21 [9]	20 [9]	27 [12]	24 [11]	32 [15]

### NOTES:

- All dimensions are in inches [mm]. Weights are in pounds [kg]. Weights are for basic unit with indicated option and control enclosure. Actual weight will vary based on project requirements for unit options, appurtenances, and controls.
- Control enclosure is standard with factory-mounted electronic controls.
- Check all national and local codes for required clearances.
- For SDL-SA-WC weights with dry coil, add dry coil weights from SDL-WC table to SDL-SA unit weights.
- See model SDR catalog for dimensional data of unit sizes 4, 5, 6, and 8.

**NOTE:** Drawings are not to scale and are not for installation purposes. Refer to [www.enviro-tec.com](http://www.enviro-tec.com) for more information. All data and dimensions are subject to change without notice.

### Model SDL-EH (Electric Heat)

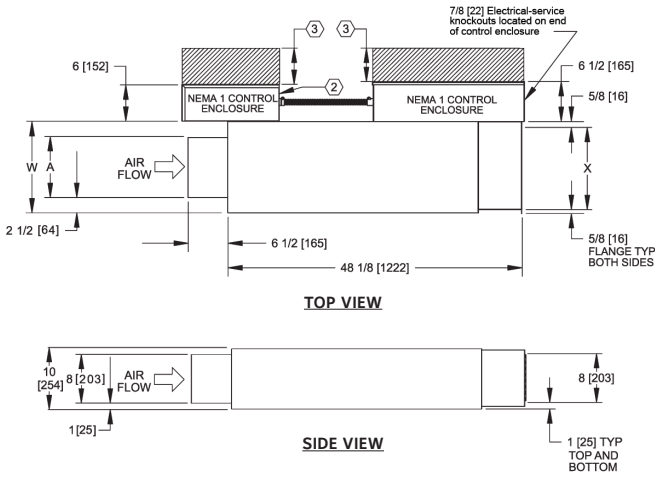

Unit Size	A	W	X	Total Weight	
				Single Wall	Double Wall
10	10" [254]	15" [381]	13-3/4" [349]	62 [28]	77 [35]
12	14" [356]	19" [483]	17-3/4" [451]	74 [34]	93 [42]
14	20" [508]	25" [635]	23-3/4" [603]	90 [41]	110 [50]
16	26" [660]	31" [787]	29-3/4" [756]	103 [47]	126 [57]

### Model SDL-SA (Sound Attenuator)

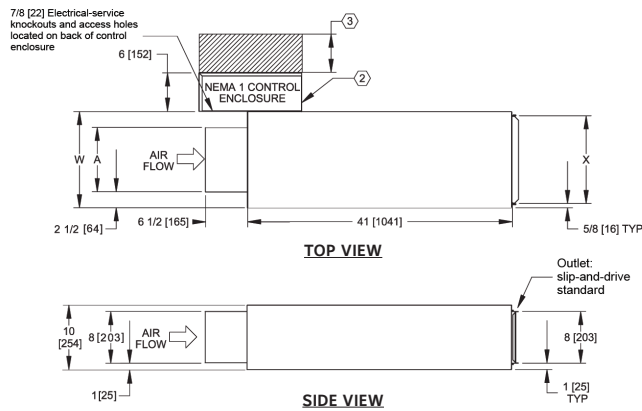

Unit Size	A	W	X	Total Weight	
				Single Wall	Double Wall
10	10" [254]	15" [381]	13-3/4" [349]	43 [19]	58 [26]
12	14" [356]	19" [483]	17-3/4" [451]	49 [22]	68 [31]
14	20" [508]	25" [635]	23-3/4" [603]	62 [28]	82 [37]
16	26" [660]	31" [787]	29-3/4" [756]	73 [33]	96 [44]

### Model SDL-SA-WC (Sound Attenuator and Hot-Water Coil)

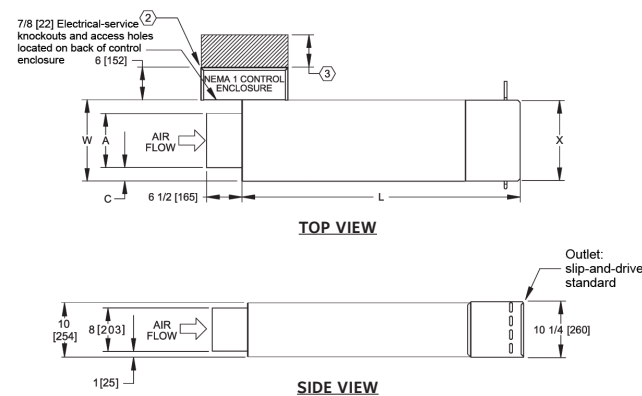

Unit Size	A	C	W	Length L		X	Total Weight (Wet Coils)		
				1, 2, 3 Row Coil	4 Row Coil		Coil Rows	Single Wall	Double Wall
10	10" [254]	6-1/2" [165]	19" [483]	47" [1194]	48" [1221]	18-3/4" [476]	1	52 [24]	67 [30]
							2	55 [25]	70 [32]
							3	58 [26]	73 [33]
							4	61 [28]	76 [34]
12	14" [356]	8-1/2" [216]	25" [635]	47" [1194]	48" [1221]	24-3/4" [629]	1	60 [27]	79 [36]
							2	64 [29]	83 [38]
							3	68 [31]	87 [39]
							4	72 [33]	91 [41]
14	20" [508]	8-1/2" [216]	31" [787]	47" [1194]	48" [1221]	30-3/4" [781]	1	75 [34]	95 [43]
							2	80 [36]	100 [45]
							3	84 [38]	104 [47]
							4	89 [40]	109 [49]
16	26" [660]	7-5/8" [194]	38" [965]	47" [1194]	48" [1221]	37-3/4" [959]	1	88 [40]	111 [50]
							2	94 [43]	117 [53]
							3	100 [45]	123 [56]
							4	105 [48]	128 [58]

# SDL Terminal Features

## STANDARD FEATURES:

### Construction

- AHRI Standard 880-certified and labeled
- 20-gauge, galvanized-steel casing
- Galvanized-steel construction
- 1/2" thick, fiberglass insulation mechanically fastened for added security

### Hot-Water Coils

- AHRI Standard 410-certified and labeled
- 1, 2, 3, 4-row coils
- Left or right-hand connections
- Tested at a minimum of 450 psig under water and rated at 300 psig working pressure at 200°F
- Aluminum-fin construction with die-formed spacer collars for uniform spacing
- Mechanically expanded copper tubes leak tested to 450 psig air pressure and rated at 300 psig working pressure at 200°F
- Male sweat-type water connections

### Primary Air Valve

- 18-gauge, galvanized-steel construction
- Low-thermal-conductance damper shaft
- Position indicator on external end of damper shaft
- Mechanical stops for open and closed position
- Multi-point, center-averaging, airflow sensor
- Balancing tees
- Plenum-rated sensor tubing

### Electrical Components

- cETL listed for safety compliance with Underwriters Laboratories Inc.® (UL) 1995
- National Electrical Manufacturers Association (NEMA) Type 1 wiring enclosure

### Electric Heat

- cETL listed as an assembly for safety compliance
- Automatic-reset primary and back-up secondary thermal limits
- Primary auto-reset high limit
- Secondary high limit
- Airflow switch
- Single-point-power connection
- Hinged, electrical-enclosure door
- Fusing per NEC

### Electronic Controls

- Patented FlowStar™ airflow sensor
- ETL listing
- NEMA 1 enclosure
- 24-volt control transformer
- Floating modulating actuator
- Balancing tees and plenum-rated tubing

## OPTIONAL FEATURES:

### Construction

- Scrim-reinforced, foil-faced insulation meeting American Society for Testing and Materials (ASTM) C1136 for mold, mildew, and humidity resistance
- 1/2" elastomeric, closed-cell-foam insulation
- Double-wall construction with a 22-gauge liner
- Mounting brackets to accept all threaded hanging rods or wire hangers
- Discharge sound attenuator (Model SDL-SA)

### Hot-Water Coils

- Coil-access plate for cleaning coil
- Coil-circuiting options for reduced water pressure drop
- Right or left-hand water connections
- Bottom and top access plates for cleaning

### Electrical Components

- Toggle disconnect switch
- Primary and secondary transformer fusing

### Electric Heat

- Proportional, solid-state relay (SSR) heater control
- Door-interlocking disconnect switches
- Disconnect (toggle or door-interlocking)
- Magnetic contactors
- P.E. switches
- Manual-reset secondary limit

### Controls

- Factory-provided controls include:
  - Verasys® ZEC Series DDC for BACnet
  - Pneumatic controls
- Consignment DDC controls (factory-mount and wire controls provided by others)